

PATENTED
PAT. <http://rbcm.biz/q=F3A63>

HERA[®]

High-Efficiency Right Angle Technical Guide

90% EFFICIENCY • 2X MORE TORQUE •
NO-HASSLE REPLACEMENT FOR WORM GEAR DRIVES

A Regal Brand

REGAL

Why HERA®?

- Up to 40% more efficient than standard worm gearing
- Dimensionally interchangeable to up to 4 sizes of worm drives for inventory consolidation
- Available with a variety of Marathon Premium Efficiency motors for even more energy savings (recommended)
- Increased Torque Density and Efficiency allow for downsizing of units and motors
- Filled with PAG460 premium synthetic lubricant for enhanced efficiency (Meets USDA H1)
- Viton Double Lip Seals protect against leaks at higher temperatures
- Longer life expectancy than that of standard worm gearing
- Rapid payback – Up to \$550 savings per year with each increment of motor HP
- Three year warranty

Worm System

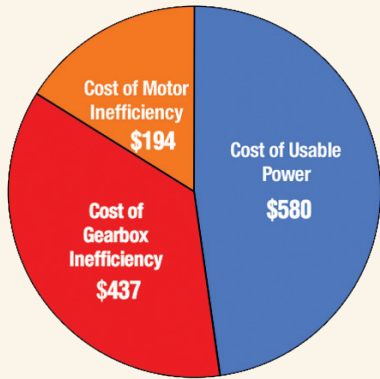

Annual Operating Cost (total): \$1,211

HERA System

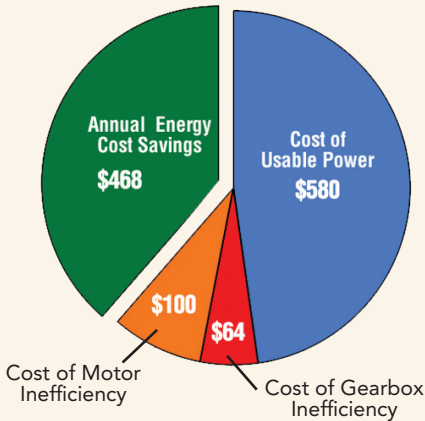

Annual Operating Cost (total): \$744

Energy Savings Example

	WORM SYSTEM	HERA SYSTEM
Gearbox Description	3.25" Worm	HERA45
Gearbox Ratio (to 1)	60/1	59.79
Motor Description	Standard 3-Ph	Marathon Globetrotter®
Motor Rating (HP)	3 HP	1.5 HP
Motor Efficiency	84%	87%
Gearbox Operating Efficiency	57%	90%
Cost of Usable Power	\$580	\$580
Cost of Gearbox Inefficiency	\$437	\$64
Cost of Motor Inefficiency	\$194	\$100
Annual Operating Cost (total)	\$1,211	\$744
Annual Energy Cost Savings		\$468

Individual results may vary.

HERA45 BENEFITS

- | | |
|------------------------------|---|
| • 39% Energy Savings | • 4700 kW-hrs Saved Annually |
| • Smaller Motor Requirements | • CO ₂ Savings = Over 2.5 tons |

Go Online to Calculate Your Savings!

www.hubcityinc.com/energy_calculator/efficiency_calculator.html

HERA® Ordering Information

HERA45

Basic Model

HERA35
HERA45
HERA55
HERA75

E

Input Style

A: Shaft Input
E: C-face Quill
P: C-face Coupled

S

Output Style

S: (Sleeve) Hollow Bore

28.01

Exact Ratio

See Ratings Chart for Available Ratios

143TC

Frame Size

See Dimensional Table for Available Frame Sizes

1.438

Bore Size

See Stock Bores Table

0259-00096

Shaft Kit

See Accessories Page For available Accessories

0259-00083

B-Base Kit

HERA® Selection As Easy As 1, 2, 3, 4

Step 1

Select Basic Model

Using the rating chart below, select basic model and ratio based on application Hp, service factor and output torque requirements (Please note color-coding for quick selection by motor HP). OR, if interchanging from competitor worm drive, use the interchange chart on back of this brochure to select the basic model.

Basic Model Quick Selection By Motor HP (1.0 Service Factor @ 1750 RPM Input)

Nom. Ratio	1/2	3/4	1	1-1/2	2	3	5	7-1/2	10	15	20
7/1	35	35	35	35	35	35	45	45	55		
10/1	35	35	35	35	35	45	45	55	55	75	75
15/1	35	35	35	35	35	45	45	55	75	75	
20/1	35	35	35	35	45	45	55	75	75		
30/1	35	35	35	45	45	55	75	75			
40/1	35	35	45	45	45	55	75				
50/1	35	45	45	45	55	75					
60/1	35	45	45	55	55	75					

Consult factory for high efficiency right angle drives suited for these power ratings.

HERA® Power Ratings (@ 1.0 Service Factor)

Nom. Ratio	INPUT RPM	Eff. (%)	HERA35			HERA45			HERA55			HERA75		
			Exact Ratio	Input HP	Output Torque (in. lbs.)	Exact Ratio	Input HP	Output Torque (in. lbs.)	Exact Ratio	Input HP	Output Torque (in. lbs.)	Exact Ratio	Input HP	Output Torque (in. lbs.)
7/1	2500	90	8.02	2.00	364	7.80	8.50	1504	7.94	13.00	2342	-	-	-
10/1	2500	90	11.42	2.00	518	11.36	7.50	1933	10.77	13.00	3177	9.58	18.00	3912
15/1	2500	90	15.60	2.00	708	15.60	7.00	2478	15.05	9.50	3244	15.05	15.00	5122
20/1	2500	90	19.93	2.00	905	19.50	5.88	2600	21.15	8.00	3839	21.15	13.00	6238
30/1	2500	90	29.10	1.67	1100	28.01	4.09	2600	30.14	6.58	4500	30.14	12.43	8500
40/1	2500	90	43.53	1.11	1100	39.98	2.87	2600	43.97	4.51	4500	37.33	10.04	8500
50/1	2500	90	52.50	0.92	1100	52.50	2.18	2600	53.03	3.74	4500	53.03	7.06	8500
60/1	2500	90	58.33	0.83	1100	59.79	1.92	2600	58.92	3.37	4500	58.92	6.36	8500
7/1	1750	90	8.02	4.23	1100	7.80	8.50	2149	7.94	13.00	3346	-	-	-
10/1	1750	90	11.42	2.97	1100	11.36	7.06	2600	10.77	12.89	4500	9.58	27.37	8500
15/1	1750	90	15.60	2.18	1100	15.60	5.14	2600	15.05	9.22	4500	15.05	17.42	8500
20/1	1750	90	19.93	1.70	1100	19.50	4.11	2600	21.15	6.56	4500	21.15	12.40	8500
30/1	1750	90	29.10	1.17	1100	28.01	2.86	2600	30.14	4.61	4500	30.14	8.70	8500
40/1	1750	90	43.53	0.78	1100	39.98	2.01	2600	43.97	3.16	4500	37.33	7.02	8500
50/1	1750	90	52.50	0.65	1100	52.50	1.53	2600	53.03	2.62	4500	53.03	4.95	8500
60/1	1750	90	58.33	0.58	1100	59.79	1.34	2600	58.92	2.36	4500	58.92	4.45	8500
7/1	1150	90	8.02	2.78	1100	7.80	6.76	2600	7.94	11.49	4500	-	-	-
10/1	1150	90	11.42	1.95	1100	11.36	4.64	2600	10.77	8.47	4500	9.58	17.99	8500
15/1	1150	90	15.60	1.43	1100	15.60	3.38	2600	15.05	6.06	4500	15.05	11.45	8500
20/1	1150	90	19.93	1.12	1100	19.50	2.70	2600	21.15	4.31	4500	21.15	8.15	8500
30/1	1150	90	29.10	0.77	1100	28.01	1.88	2600	30.14	3.03	4500	30.14	5.72	8500
40/1	1150	90	43.53	0.51	1100	39.98	1.32	2600	43.97	2.07	4500	37.33	4.62	8500
50/1	1150	90	52.50	0.42	1100	52.50	1.00	2600	53.03	1.72	4500	53.03	3.25	8500
60/1	1150	90	58.33	0.38	1100	59.79	0.88	2600	58.92	1.55	4500	58.92	2.92	8500
7/1	850	90	8.02	2.06	1100	7.80	5.00	2600	7.94	8.49	4500	-	-	-
10/1	850	90	11.42	1.44	1100	11.36	3.43	2600	10.77	6.26	4500	9.58	13.30	8500
15/1	850	90	15.60	1.06	1100	15.60	2.50	2600	15.05	4.48	4500	15.05	8.46	8500
20/1	850	90	19.93	0.83	1100	19.50	2.00	2600	21.15	3.19	4500	21.15	6.02	8500
30/1	850	90	29.10	0.57	1100	28.01	1.39	2600	30.14	2.24	4500	30.14	4.23	8500
40/1	850	90	43.53	0.38	1100	39.98	0.97	2600	43.97	1.53	4500	37.33	3.41	8500
50/1	850	90	52.50	0.31	1100	52.50	0.74	2600	53.03	1.27	4500	53.03	2.40	8500
60/1	850	90	58.33	0.28	1100	59.79	0.65	2600	58.92	1.14	4500	58.92	2.16	8500
7/1	100	90	8.02	0.24	1100	7.80	0.59	2600	7.94	1.00	4500	-	-	-
10/1	100	90	11.42	0.17	1100	11.36	0.40	2600	10.77	0.74	4500	9.58	1.56	8500
15/1	100	90	15.60	0.12	1100	15.60	0.29	2600	15.05	0.53	4500	15.05	1.00	8500
20/1	100	90	19.93	0.10	1100	19.50	0.24	2600	21.15	0.38	4500	21.15	0.71	8500
30/1	100	90	29.10	0.07	1100	28.01	0.16	2600	30.14	0.26	4500	30.14	0.50	8500
40/1	100	90	43.53	0.04	1100	39.98	0.11	2600	43.97	0.18	4500	37.33	0.40	8500
50/1	100	90	52.50	0.04	1100	52.50	0.09	2600	53.03	0.15	4500	53.03	0.28	8500
60/1	100	90	58.33	0.03	1100	59.79	0.08	2600	58.92	0.13	4500	58.92	0.25	8500

Specifications are subject to change without notice

Step 2

Select Input Type

- E - C-face (quill), Select available frame size (G)
- P - C-face (coupled), Select available frame size (G)
- A - Shaft input, Select shaft diameter desired (G)

HERA® Model Dimensions

E - C-face (quill)

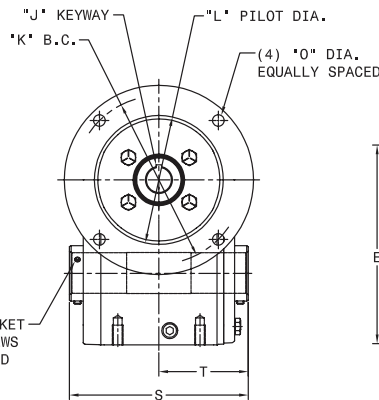
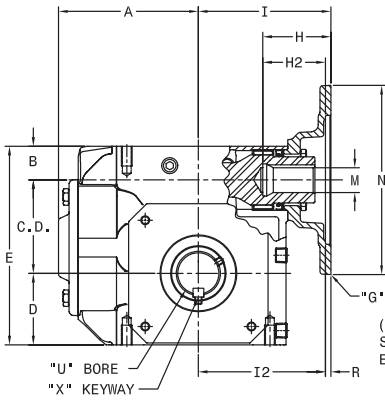

P - C-face (coupled)

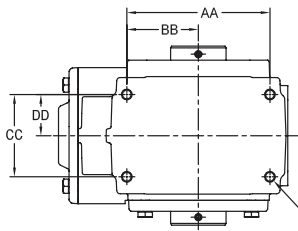
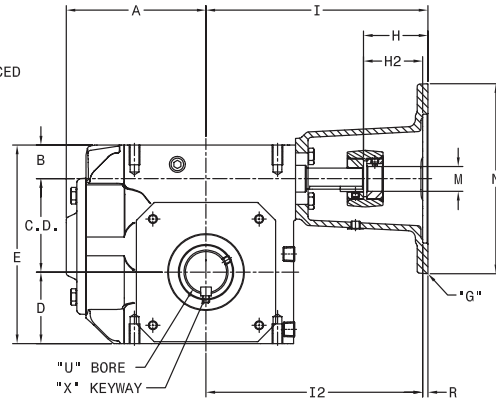

Modified units are available, consult factory. THESE UNITS CAN BE FURNISHED WITH SOLID OUTPUT SHAFT ON SPECIAL ORDERS.

SHAFT MOUNTED UNITS REQUIRE TORQUE ARMS. TORQUE ARM KITS ARE AVAILABLE.

- (4) "EE" NC (TOP AND BOTTOM)
- "FF" DEEP TOP
- "GG" DEEP BOTTOM

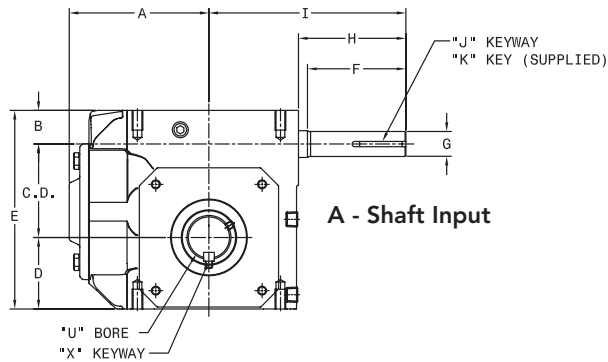

Step 3

Select Output Arrangement

- S - Hollow Bore (choose bore size)
- Shaft Output - choose shaft kit from accessory page
- Note: must order appropriate bore size in unit required for shaft kit

Stock Bores

U	X
Hera35	
3/4	3/16 X 3/32
7/8	3/16 X 3/32
1	1/4 X 1/8
1-1/8	1/4 X 1/8
1-3/16	1/4 X 1/8
1-1/4	1/4 X 1/8
1-7/16	3/8 X 1/8
Hera45	
1	1/4 X 1/8
1-1/8	1/4 X 1/8
1-3/16	1/4 X 1/8
1-1/4	1/4 X 1/8
1-7/16	3/8 X 1/8
1-1/2	3/8 X 1/8
Hera55	
1-3/16	1/4 X 1/8
1-1/4	1/4 X 1/8
1-7/16	3/8 X 3/16
1-1/2	3/8 X 3/16
1-5/8	3/8 X 3/16
1-11/16	3/8 X 3/16
1-3/4	3/8 X 3/16
1-7/8	1/2 X 1/4
1-15/16	1/2 X 3/16
2	1/2 X 3/16
2-3/16	1/2 X 1/8
Hera75	
1-7/16	3/8 X 3/16
1-1/2	3/8 X 3/16
1-15/16	1/2 X 1/4
2	1/2 X 1/4
2-3/16	1/2 X 1/4
2-7/16	5/8 X 5/16
3	3/4 X 3/8
3-7/16	7/8 X 1/4

Model Dimensions

Model	C.D.	A	B	D	E	AA	BB
Hera35	2.509	4.25	1.178	2.062	5.750	4.188	2.094
Hera45	3.263	4.88	1.175	2.500	6.938	5.000	2.500
Hera55	3.675	6.15	2.200	3.500	9.375	7.500	3.750
Hera75	4.287	8.36	2.650	4.438	11.375	8.500	4.250

Model	CC	DD	EE	FF	GG	S	T
Hera35	2.750	1.375	5/16 UNC	.63	.63	5.50	2.75
Hera45	2.875	1.438	3/8 UNC	.69	.69	6.25	3.13
Hera55	4.000	2.000	7/16 UNC	.88	.88	7.50	3.75
Hera75	5.000	2.500	5/8 UNC	1.00	1.00	9.50	4.75

Shaft Input Dimensions

Model	Size Ref.	F	G	H	I	J	K
Hera35AS	18	1.56	.6245/.6235	1.94	4.88	3/16 X 3/32	3/16 SQ X 1-1/4
	21	1.81		2.19	5.13		3/16 SQ X 1-1/2
	24	2.00	.7495/.7485	2.38	5.31		
Hera45AS	24	2.00	.7495/.7485	2.38	5.50	3/16 X 3/32	3/16 SQ X 1-1/2
	26	2.81		3.19	6.31		
	30	3.44	.8745/.8735	3.76	6.88		
Hera55AS	32	4.00		4.32	7.44		
	32	2.07	.8745/.8735	2.38	6.75	3/16 X 3/32	3/16 SQ X 1-1/2
	38	3.70	.9995/.9985	4.01	8.38	1/4 X 1/8	1/4 SQ X 2-1/4
	42	4.88	1.2495/1.2485	5.19	9.56		
	42	2.07	.8745/.8735	2.38	7.63	3/16 X 3/32	3/16 SQ X 1-1/2
Hera75AS	42	4.00	1.2495/1.2485	4.31	9.56	1/4 X 1/8	1/4 SQ X 2-1/4
	52	5.00		5.44	10.69		1/4 SQ X 3

C-Face Input Dimensions

C-FLANGE MODELS	ES MODELS				PS MODELS				ES & PS MODELS								
Model	G	H	H2	I	I2	H	H2	I	I2	J	K	L	M	N	O	R	Wt. Lbs.
Hera35	56C	2.27	N/A	4.44	N/A	2.25	N/A	7.57	N/A	3/16 X 3/32	5.875	4.501/4.503	.625	6.63	13/32	.188	30
	143TC	2.38											.875				
Hera45	56C	2.27	N/A	4.63	N/A	2.25	N/A	7.76	N/A	3/16 X 3/32	5.875	4.501/4.503	.625	6.63	13/32	.188	43
	143TC	2.38											.875				
	182TC	N/A	2.89	N/A	5.06	N/A	3.25	N/A	8.76	1/4 X 1/8	7.250	8.501/8.503	1.125	9.00	17/32	.188	50
Hera55	56C	2.27	N/A	5.57	N/A	2.25	N/A	9.00	N/A	3/16 X 3/32	5.875	4.501/4.503	.625	6.63	13/32	.188	82
	143TC	2.38											.875			.188	
	182TC	N/A	2.89	N/A	6.33	N/A	3.25	N/A	10.00	1/4 X 1/8	7.250	8.501/8.503	1.125	9.00	17/32	.188	90
	213TC		3.63							5/16 X 5/32			1.375				
256TC		3.88				N/A			3/8 X 3/16			1.625					
Hera75	56C	2.27	N/A	6.45	N/A	2.25	N/A	9.88	N/A	3/16 X 3/32	5.875	4.501/4.503	.625	6.63	13/32	.188	167
	143TC	2.38											.875				
	182TC	N/A	2.89	N/A	7.21	N/A	3.25	N/A	10.88	1/4 X 1/8	7.250	8.501/8.503	1.125	9.00	17/32	.188	175
	213TC		3.63							5/16 X 5/32			1.375				
	256TC		3.88				N/A			3/8 X 3/16			1.625				

Specifications are subject to change without notice

Step 4

Select Accessories

- B - interchange base (required if interchanging to larger size worm gear reducer) provides appropriate "D" dimension and tapped mounting hole dimensions & pattern
- T - Base (includes B-base above) provides means to bolt unit from above mounting surface and matches competitor worm mounting base bolt patterns
- F - flanges, provide means for side mounting
- Other available accessories: Vertical base kits, torque arm kits, C-flange adapter kits

Plug-In Shaft Kits

Series	Size Ref.	Stock Bore Required	Double Ext Kit No.	Single Ext Kit No.	S	T	T2	U	V	W	W2	X	Y	Key(s) Furnished	WT. LBS.
Hera35	18	1.438	0259-00135	0259-00136	8.62	4.31	2.97	.875	2.05	1.38	1.34	3/16 x 3/32	1.13	3/16 SQ X 1-1/8	4.1
	21		0259-00137	0259-00138	9.38	4.69	2.97	1.000	2.43	1.76	1.72	1/4 X 1/8	1.50	1/4 SQ X 1-1/2	4.4
	24		0259-00139	0259-00140	10.28	5.14	2.97	1.125	2.88	2.21	2.17	1/4 X 1/8	1.75	1/4 SQ X 1-3/4	4.9
Hera45	24	1.438	0259-00092	0259-00093	10.28	5.14	3.45	1.125	2.50	1.77	1.69	1/4 X 1/8	1.50	1/4 SQ X 1-1/2	5.2
	26		0259-00094	0259-00095	11.25	5.63	3.44	1.125	2.99	2.25	2.18	1/4 X 1/8	2.00	1/4 SQ X 1-3/4	5.7
	30		0259-00096	0259-00097	13.50	6.75	3.45	1.250	4.11	3.38	3.30	1/4 X 1/8	2.25	1/4 SQ X 2-1/4	6.6
	32		0259-00098	0259-00099	14.12	7.06	3.45	1.375	4.42	3.69	3.64	5/16 X 5/32	2.50	5/16 SQ X 2-3/8	7.3
Hera55	32	1.938	0259-00117	0259-00118	14.12	7.06	4.06	1.375	3.91	3.06	3.00	5/16 X 5/32	2.50	5/16 SQ X 2-3/8	10.0
	35		0259-00167	0259-00168	14.12	7.06	4.06	1.500	3.91	3.06	3.00	3/8 x 3/16	2.50	3/8 SQ X 2	10.0
	38		0259-00119	0259-00120	15.50	7.75	4.06	1.625	4.60	3.75	3.69	3/8 X 3/16	2.81	3/8 SQ X 2-1/2	11.8
	42		0259-00121	0259-00122	16.24	8.12	4.06	1.875	4.97	4.12	4.03	1/2 X 1/4	3.31	1/2 SQ X 3-1/4	13.8
Hera75	42	2.438	0259-00153	0259-00154	16.24	8.12	5.12	1.875	4.00	3.06	3.00	1/2 X 1/4	2.56	1/2 SQ X 2-1/2	TBD
	52		0259-00155	0259-00156	18.12	9.06	5.12	2.000	4.94	4.00	3.94	1/2 X 1/4	3.56	1/2 SQ X 3-1/2	TBD
	60		0259-00164	0259-00165	20.00	10.00	5.12	2.250	5.88	4.94	4.88	1/2 X 1/4	3.56	1/2 SQ X 3-1/2	TBD

Base Kits

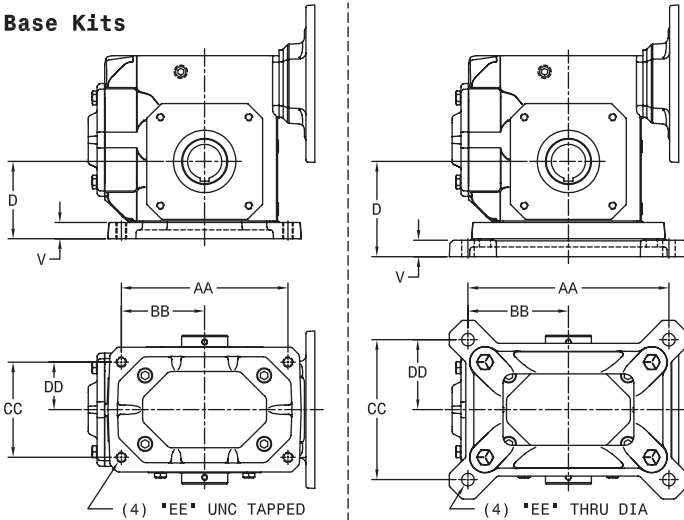

B-Base Kit

Hera B-bases provide a drop-in mounting solution when replacing comparable rated worm gear reducers.

T-Base Kit

Hera T-bases provide a drop-in mounting solution when replacing comparable rated worm gear reducers that also are utilizing a horizontal mounting base.

B - Base Kits

Series	B-Base Kit No.	Shipping Wt. Lbs.	Size Ref.	D	V	AA	BB	CC	DD	EE
Hera35	0259-00130	1.3	21	2.281	0.22	5.00	2.50	2.88	1.44	3/8 UNC
	0259-00131	2.0	24	2.500	0.38	5.00	2.50	2.88	1.44	3/8 UNC
Hera45	0259-00082	2.5	26	2.938	0.38	6.38	3.19	3.38	1.69	3/8 UNC
	0259-00083	4.3	30	3.25	0.69	7.00	3.50	4.00	2.00	7/16 UNC
Hera55	0259-00084	5.0	32	3.500	0.88	7.50	3.75	4.00	2.00	7/16 UNC
	0259-00112	4.0	38	3.875	0.38	8.50	4.25	4.75	2.38	1/2 UNC
Hera75	0259-00113	7.5	42	4.438	0.88	8.50	4.25	5.00	2.50	5/8 UNC
	0259-00150	13	52	5.313	0.79	11.00	5.50	5.81	2.91	5/8 UNC
	0259-00162	21	60	6.500	1.50	12.75	6.38	6.38	3.19	5/8 UNC

T - Base Kits

Series	T-Base Kit No.	Shipping Wt. Lbs.	Size Ref.	D	V	AA	BB	CC	DD	EE
Hera35	0259-00132	3.0	18	2.75	0.63	5.75	2.88	4.5	2.25	0.41
	0259-00133	4.8	21	3.000	0.66	6.38	3.19	4.69	2.34	0.47
	0259-00134	9.0	24	3.25	0.69	7.06	3.53	4.88	2.44	0.47
Hera45	0259-00186	6.0	24	3.25	0.69	7.06	3.53	4.88	2.44	0.47
	0259-00085	7.0	26	3.688	0.69	8.00	4.00	5.25	2.63	0.53
	0259-00086	9.5	30	4.000	0.69	8.44	4.22	5.88	2.94	0.53
Hera55	0259-00087	11.5	32	4.375	0.81	9.5	4.75	6.13	3.06	0.53
	0259-00114	6.5	32	4.375	0.81	9.5	4.75	6.13	3.06	0.53
	0259-00115	12.5	38	4.812	0.88	10.38	5.19	7.00	3.50	0.59
Hera75	0259-00116	19	42	5.438	0.94	11.13	5.56	7.63	3.81	0.66
	0259-00151	13	42	5.438	0.94	11.13	5.56	7.63	3.81	0.66
	0259-00152	27	52	6.438	1.06	14.13	7.06	8.38	4.19	0.78
	0259-00163	52	60	7.750	1.12	16.50	8.25	9.50	4.75	0.91

Specifications are subject to change without notice

Plug-In Shaft Kits

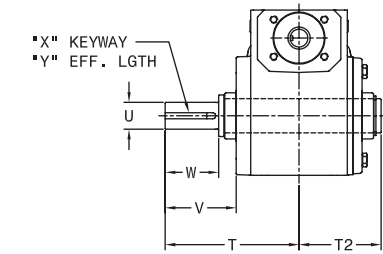

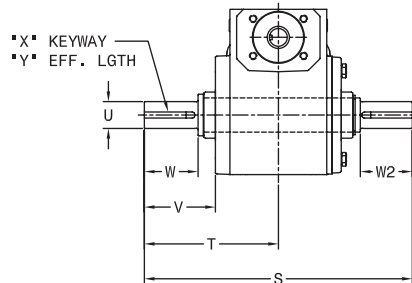

Single Extended

Note: Single Extended Kit can be installed from either side.



Double Extended

Additional Accessories Available

 <p>Torque Arm Kit</p>	 <p>Output Cover Kit</p> <p>(COVERS THE END OF THE OUTPUT SLEEVE)</p>	
Series	Part No.	Part No.
Hera35	0259-00125	0259-00184
Hera45	0259-00078	0259-00185
Hera55	0259-00107	NA
Hera75	0259-00144	NA

Contact Factory for Dimensions on above kits

F-Flange Kits

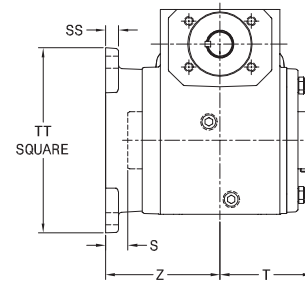
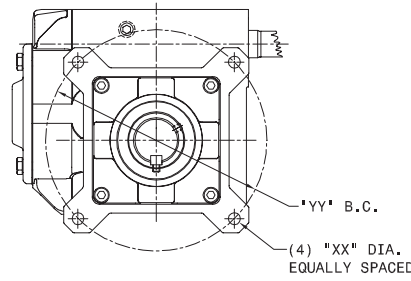

Note: Flange Kit can be installed on either side.

F-Flange Kits

Series	F-Flange Kit No.	Shipping Wt. Lbs.	Size Ref.	S	T	Z	SS	TT	XX	YY
Hera35	0259-00141	8	18	0.44	2.75	3.19	0.38	5.00	0.34	5.88
	0259-00142	10	21	0.81	2.75	3.56	0.44	6.00	0.41	7.00
	0259-00143	10	24	0.75	2.75	3.50	0.44	6.27	0.41	7.50
Hera45	0259-00088	10	24	0.76	3.13	3.88	0.44	6.27	0.41	7.50
	0259-00089	12	26	0.31	3.13	3.44	0.50	6.67	0.41	8.00
	0259-00090	14	30	0.15	3.13	3.28	0.50	7.37	0.41	9.00
Hera55	0259-00123	15	32	0.04	3.75	3.79	0.50	7.37	0.41	9.00
	0259-00124	20	42	0.34	3.75	4.09	0.62	9.65	0.56	11.5
Hera75	0259-00157	20	42	0.31	4.75	5.06	0.62	9.65	0.56	11.5
	0259-00158	25	52	0.71	4.75	4.46	0.75	11.75	0.69	14.00
	0259-00166	30	60	1.82	4.75	6.57	0.75	SPEC	0.69	15.63

Vertical Base Kits

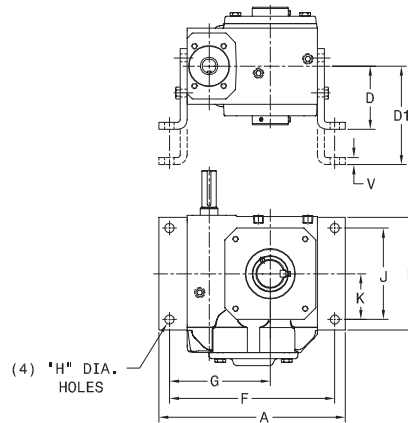
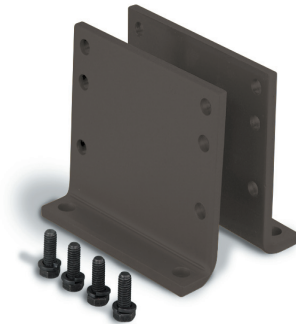

Vertical Base Kits

Series	Vertical Base Kit No.	Shipping Wt. Lbs.	A	B	D	D1	F	G	H	J	K	V
Hera35	0259-00159	7	8.25	5	3	4.38	7.37	4.5	0.44	4	2	0.25
Hera45	0259-00106	10	9.94	6	3.38	5.25	8.81	5.38	0.5	4.88	2.44	0.38
Hera55	0259-00160	15	13	9	4.69	6.25	11.88	7.13	0.56	6.13	3.06	0.38
Hera75	0259-00161	35	16.26	10	5	7.5	14.88	8.69	0.69	7.88	3.94	0.5

Output Bushing Kits for HERA35 and HERA45

Bushing Kit #	Bore Size Item #1	Key Item #2	Key Item #3	Set Screws Item #4
0259-00178	3/4	3/8 x 1/4 x 3	3/16 x 3/16 x 3	1/4-20 X 5/8
0259-00179	7/8	3/8 x 1/4 x 3	3/16 x 3/16 x 3	1/4-20 X 1/2
0259-00180	1	3/8 x 1/4 x 3	1/4 x 1/4 x 3	1/4-20 X 1/2
0259-00181	1-1/8	3/8-1/4 STEP x 3	N/A	1/4-20 X 1/2
0259-00182	1-3/16	3/8-1/4 STEP x 3	N/A	1/4-20 X 3/8
0259-00183	1-1/4	3/8-1/4 STEP x 3	N/A	1/4-20 X 3/8

Output Bushing Kits

Output Bushing Kits provide a means to adapt the Stock Bore hollow bore diameter to the most popular shaft diameters on driven equipment. Quick and easy installation. Bushing Kits fit both Models HERA35 and HERA45. Note: 1.438" stock bore required.

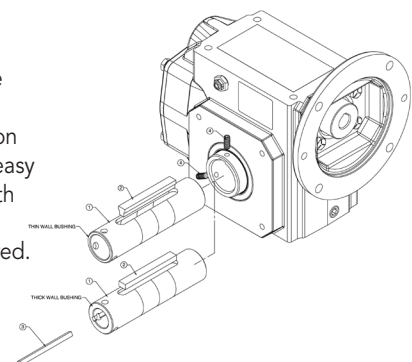

Specifications are subject to change without notice

Riser Block Kits

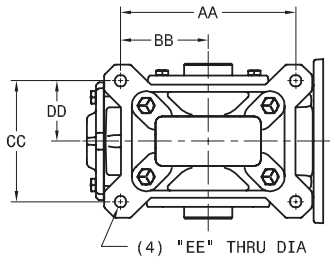

Riser Block Kits

Riser Block Kits provide a clear top mounting surface above the motor flange for mounting below machine framework etc. Kits include T-base plates and mounting hardware.

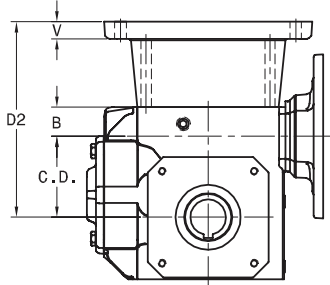

Riser Block Kits

Series	Kit No.	Shipping Wt. Lbs.	Size Ref.	C.D.	B	D2	V	AA	BB	CC	DD	EE
Hera35	0259-00170	6.2	17	2.509	1.178	5.99	0.63	5.75	2.88	4.5	2.25	0.41
	0259-00171	6.8	20			6.24	0.66	6.38	3.19	4.69	2.34	0.47
	0259-00172	13.1	23			7.88	0.69	7.06	3.53	4.88	2.44	0.47
Hera45	0259-00173	12.2	23	3.263	1.175	7.88	0.69	7.06	3.53	4.88	2.44	0.47
	0259-00174	14.5	26			8.21	0.69	8.00	4.00	5.25	2.63	0.53
	0259-00175	18.0	30			8.63	0.69	8.44	4.22	5.88	2.94	0.53
Hera55	0259-00176	20.0	35	3.675	2.200	9.27	0.81	9.50	4.75	6.13	3.06	0.53
	0259-00177	32.0	40			10.83	0.94	11.13	5.56	7.63	3.81	0.66

Nema "C" Flange Adaptor Kits

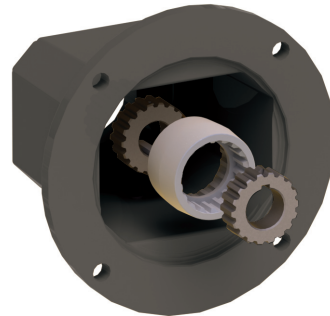
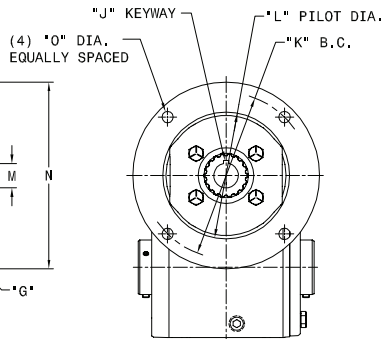
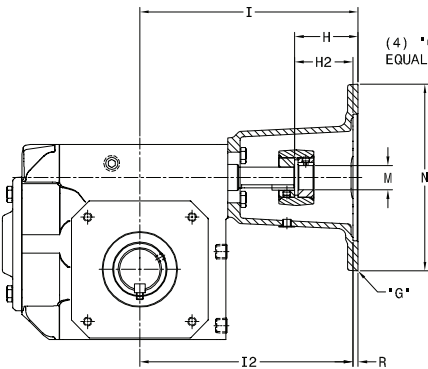

C-Flange Kits

Series	Base Unit Required	C-Flange Kit No.	Shipping Wt. Lbs.	G	H	H2	I	I2	J	K	L	M	N	O	R
Hera35	AS24	0259-00079	12	56C	2.25	N/A	7.57	N/A	3/16 X 3/32	5.875	4.501/4.503	.625	6.63	13/32	.188
		0259-00080	14	143TC								.875			
Hera45	AS24	0259-00079	12	56C	2.25	N/A	7.76	N/A	3/16 X 3/32	5.875	4.501/4.503	.625	6.63	13/32	.188
		0259-00080	14	143TC								.875			
		0259-00081	20	182TC	N/A	3.25	N/A	8.76	1/4 X 1/8	7.250	8.501/8.503	1.125	9.00	17/32	.188
Hera55	AS32	0259-00108	12	56C	2.25	N/A	9.00	N/A	3/16 X 3/32	5.875	4.501/4.503	.625	6.50	13/32	.188
		0259-00109	14	143TC								.875			.188
		0259-00110	20	182TC	N/A	3.25	N/A	10.00	1/4 X 1/8	7.250	8.501/8.503	1.125	9.00	17/32	.188
		0259-00111	20	213TC					5/16 X 5/32			1.375			
Hera75	AS32	0259-00108	12	56C	2.25	N/A	9.88	N/A	3/16 X 3/32	5.875	4.501/4.503	.625	6.63	13/32	.188
		0259-00109	14	143TC								.875			
		0259-00110	20	182TC	N/A	3.34	N/A	10.88	1/4 X 1/8	7.250	8.501/8.503	1.125	9.00	17/32	.188
		0259-00111	20	213TC					5/16 X 5/32			1.375			

Specifications are subject to change without notice

Worm Reducer Interchange

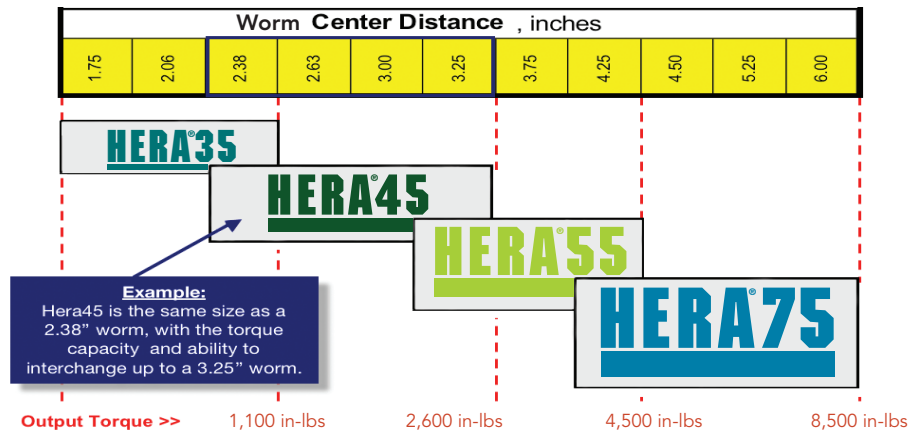

Competitor Interchange Guide

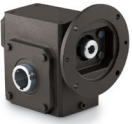
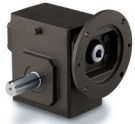

Solid Output Shaft-NEMA C Flange Reducer (Quill Input)										
CENTER DISTANCE (Inches)	1.75	2.06	2.38	2.62	3.00	3.25	3.75	4.25	5.25	6.00
HERA - ES w/plug-in shaft kit	Hera35ES	Hera35ES*	Hera35ES*	Hera45ES	Hera45ES*	Hera45ES*	Hera55ES	Hera55ES*	Hera75ES*	Hera75ES*
BALDOR	F918	F921	F924	F926	F930	F932	F938	—	—	—
BOSTON	F718	F721	F724	F726	F730	F732	F738	—	F752	F760
Dodge-Tigear-2	17Q	20Q	23Q	26Q	30Q	—	35Q	—	—	—
Falk-Omnibox	1175WBM	1206WBM	1238WBM	1262WBM	1300WBM	1325WBM	—	1425WBM	1525WBM	1600WBM
Morse-Raider	175Q	206Q	237Q	262Q	300Q	325Q	375Q	450Q	516Q	600Q
Solid Output Shaft-NEMA C Flange Reducer (Coupled Input)										
CENTER DISTANCE (Inches)	1.75	2.06	2.38	2.62	3.00	3.25	3.75	4.25	5.25	6.00
HERA - PS w/plug-in shaft kit	Hera35PS	Hera35PS*	Hera35PS*	Hera45PS	Hera45PS*	Hera45PS*	Hera55PS	Hera55PS*	Hera75PS*	Hera75PS*
BALDOR	LF918	LF921	LF924	LF926	LF930	LF932	LF938	—	—	—
BOSTON	RF718	RF721	RF724	RF726	RF730	RF732	RF738	—	RF752	RF760
Dodge-Tigear-2	17A	20A	23A	26A	30A	—	35A	—	—	—
Falk-Omnibox	1175WBF	1206WBF	1238WBF	1262WBF	1300WBF	1325WBF	—	1425WBF	1525WBF	1600WBF
Morse-Raider	175C	206C	237C	262C	300C	325C	375C	450C	516C	600C
Solid Output Shaft-Non-Flanged Reducer (Basic Unit)										
CENTER DISTANCE (Inches)	1.75	2.06	2.38	2.62	3.00	3.25	3.75	4.25	5.25	6.00
HERA - AS w/plug-in shaft kit	Hera35AS	Hera35AS*	Hera35AS*	Hera45AS	Hera45AS*	Hera45AS*	Hera55AS	Hera55AS*	Hera75AS*	Hera75AS*
BALDOR	S918	S921	S924	S926	S930	S932	S938	—	S952	S960
BOSTON	718	721	724	726	730	732	738	—	752	760
Dodge-Tigear-2	17S	20S	23S	26S	30S	—	35S	—	—	—
Falk-Omnibox	1175WB	1206WB	1238WB	1262WB	1300WB	1325WB	—	1425WB	1525WB	1600WB
Morse-Raider	175U	206U	237U	262U	300U	325U	375U	450U	516U	600U
Hollow Output Shaft-NEMA C Flange Reducer (Quill Input)										
CENTER DISTANCE (Inches)	1.75	2.06	2.38	2.62	3.00	3.25	3.75	4.25	5.25	6.00
HERA - ES	Hera35ES	Hera35ES*	Hera35ES*	Hera45ES	Hera45ES*	Hera45ES*	Hera55ES	Hera55ES*	Hera75ES*	Hera75ES*
BALDOR	HF918	HF921	HF924	HF926	HF930	HF932	HF938	—	—	—
BOSTON	HF718	HF721	HF724	HF726	HF730	HF732	HF738	—	—	—
Dodge-Tigear-2	17QH	20QH	23QH	26QH	30QH	—	35QH	—	—	—
Falk-Omnibox	1175WBQM	1206WBQM	—	1262WBQM	1300WBQM	1325WBQM	—	1425WBQM	1525WBQM	1600WBQM
Morse-Raider	175QH	206QH	237QH	262QH	300QH	325QH	375QH	450QH	516QH	600QH
Hollow Output Shaft-NEMA C Flange Reducer (Coupled Input)										
CENTER DISTANCE (Inches)	1.75	2.06	2.38	2.62	3.00	3.25	3.75	4.25	5.25	6.00
HERA - PS	Hera35PS	Hera35PS*	Hera35PS*	Hera45PS	Hera45PS*	Hera45PS*	Hera55PS	Hera55PS*	Hera75PS*	Hera75PS*
BALDOR	HLF918	HLF921	HLF924	HLF926	HLF930	HLF932	HLF938	—	—	—
BOSTON	HRF718	HRF721	HRF724	HRF726	HRF730	HRF732	HRF738	—	—	—
Dodge-Tigear-2	17AH	20AH	23AH	26AH	30AH	—	35AH	—	—	—
Falk-Omnibox	1175WBQF	1206WBQF	—	1262WBQF	1300WBQF	1325WBQF	—	1425WBQF	1525WBQF	1600WBQF
Morse-Raider	175CH	206CH	237CH	262CH	300CH	325CH	375CH	450CH	516CH	600CH
Hollow Output Shaft - Non-Flanged Reducer (Basic Unit)										
CENTER DISTANCE (Inches)	1.75	2.06	2.38	2.62	3.00	3.25	3.75	4.25	5.25	6.00
HERA - AS	Hera35AS	Hera35AS*	Hera35AS*	Hera45AS	Hera45AS*	Hera45AS*	Hera55AS	Hera55AS*	Hera75AS*	Hera75AS*
BALDOR	HS918	HS921	HS924	HS926	HS930	HS932	HS938	—	—	—
Boston	H718	H721	H724	H726	H730	H732	H738	—	—	—
Dodge-Tigear-2	17SH	20SH	23SH	26SH	30SH	—	35SH	—	—	—
Falk-Omnibox	1175WBQ	1206WBQ	1238WBQ	1262WBQ	1300WBQ	1325WBQ	—	1425WBQ	1525WBQ	1600WBQ
Morse-Raider	175UH	206UH	237UH	262UH	300UH	325UH	375UH	450UH	516UH	600UH

*B-Interchange Base Kit required for foot mounting (see accessory page)
Information for reference only, consult factory for information on your specific application.



2914 Industrial Avenue
Aberdeen, SD 57402 USA
PH: 605-225-0360
FAX: 605-225-0567

www.hubcityinc.com



Made in U.S.A.

A Regal Brand



www.regalbeloit.com